



PARAFUSO RETORNO

BOMBA INJETORA - 01

4008 058 Valv.Reteção Perkins/Bosch Rosca fina	4008 237 Válvula de retenção Perkins bomba CAV 10X22 fio 1.5	4008 308 18 Retorno MBB 8mm 1.0	4008 308 20 Retorno 8mm 1.25	4008 308 161 Retorno MWM/F-1000 8mm 1.0	4008 306 12 Retorno Bosch M6x1,0 curto	6153 14 27 Retorno MBB 14/x27mm 14mm Rosca Interna	4008 082 Filtro Entrada Bosch/MWM 14mm
4008 306 18 Retorno duplo Scania/D-20 Ford Cargo	0863 002 Retorno duplo Ford Cargo Q20/SSB	0863 004 Retorno duplo Perkins	4008 314 25 Retorno 14mm	4008 312 118 Retorno (1/2"x20Fios) Perkins	4008 351 61 Bomba injetora Perkins 8mm fio 0.75 duplo	6153 10 20 Retorno bomba injetora 10mm 1.0 MBB/SSB	4008 312 25 Retorno 12x25mm
4008 516 24 Retorno Ford 5/16x24	4008 16 39 Parafuso oco 16mm	4008 17 38 Parafuso oco 17mm Valmet	0863 003 Duplo filtro MBB/Scania 14x16mm	6153 12 22 Parafuso oco Bomba inj. Sprinter 12x22mm	6153 12 27 Parafuso oco bloco motor Sprinter 12x27mm	4008 351 612 Bomba injetora Perkins 8mm fio 0.75	4008 059 Banjo 3/8-24F Perkins
4008 14 42 Corpo Duplo Freio Ar 14mm	4008 14 46 Corpo Duplo Freio Ar 16mm	4008 212 25 Válvula Retorno MWM	4008 214 25 Válvula Retorno 352/1113 MBB	4008 064 Valv.Retorno Cav Rosca Fina	0863 010 Valv.Retorno F-4000	0863 001 Valv.Retorno Scania	



ARRUELAS DE ASSENTAMENTO/VEDAÇÃO

BOMBA INJETORA - 02



0430 09 005
0430 09 010
0430 09 015
0430 09 020
0430 09 025
SCANIA
Calço de bico



0430 98 005
0430 98 010
0430 98 015
0430 98 020
0430 98 025
FORD CARGO
Calço de bico



0430 11 005
0430 11 010
0430 11 015
0430 11 020
0430 11 025
MBB
Calço de bico



0430 07 005
0430 07 010
0430 07 015
0430 07 020
0430 07 025
CUMMINS
Calço de bico



0430 315 85
Calço Bico Mbb
1935 3,15x8,5



0470 96 18
Assento bico
MWM/112/111
Ø9.6x18.3x1.8



0470 9 18
Assento Bico
D10/D20 GCO
Ø9.6x18.3x1.4



0470 9 201
Assento Bico
MBB 1113
Ø9.6x20x0.9



0470 95 18
Assento Bico
Trator Ford 7610
Ø9.6x18.3x0.9



0470 9 20
Assento bico
Perkins/MWM
Ø9.6x20x1.4



0470 9 202
Assento bico
MWM/VOLVO
Ø9.6x20x1.8



0470 74 005
Assento bico
Mitsubisch
Ø7.4x15x0.5



0470 74 009
Assento bico
Cummins
Ø7.4x15x0.9



0470 74 014
Assento bico
Cummins
Ø7.4x15x1.4



0470 74 15
Assento bico
Maxxion
Ø7.4x15x1.8



0470 74 021
Assento bico
MWM
Ø7.4x15x2.1



0470 74 024
Assento bico
Cummins
Ø7.4x15x2.4



0470 7 15
Assento bico
Cummins/MWM
Common Rail/Sprinter
Ø7.4x15x1.4



0470 74 032
Assento bico
Cummins
Ø7.4x15x3.2



0470 95 20
Assento bico
MBB 1934
Ø9.5x20x0.5



0470 10 21
Assento bico
Perkins
Ø10.2x21.2x1.8



0470 12 17
Assento bico
Mitsubishi
Ø12.1x17x1.4



0470 8 14
Assento bico
Hilux
Ø8.2x15.6x1.4



0470 12 181
Assento bico
Hyundai
Ø12.1x18.3x1.4



0470 14 201
Assento bico
Ducato/Topic/Besta
Ø14.3x20x1.8



0470 7 151
Assento bico
MBB 1938
motor 457



0410 42 121
Ø 4x10x0.5
Cônica



0474 6 10
Cummins
Ø6.3x10.2x0.9
dupla cobre



0474 8 12
MBB
Ø8.2x12.1x0.9
dupla cobre



0474 8 128
Hilux
Ø8.3x12.8x1.0
dupla aluminio



0473 12 19
Arruela vedação
Hilux
Ø12x19x1.0
aluminio



0473 12 23
Arruela vedação
Frontier
Ø12x23x1.0
aluminio



BOSCH

BOMBA INJETORA - 03

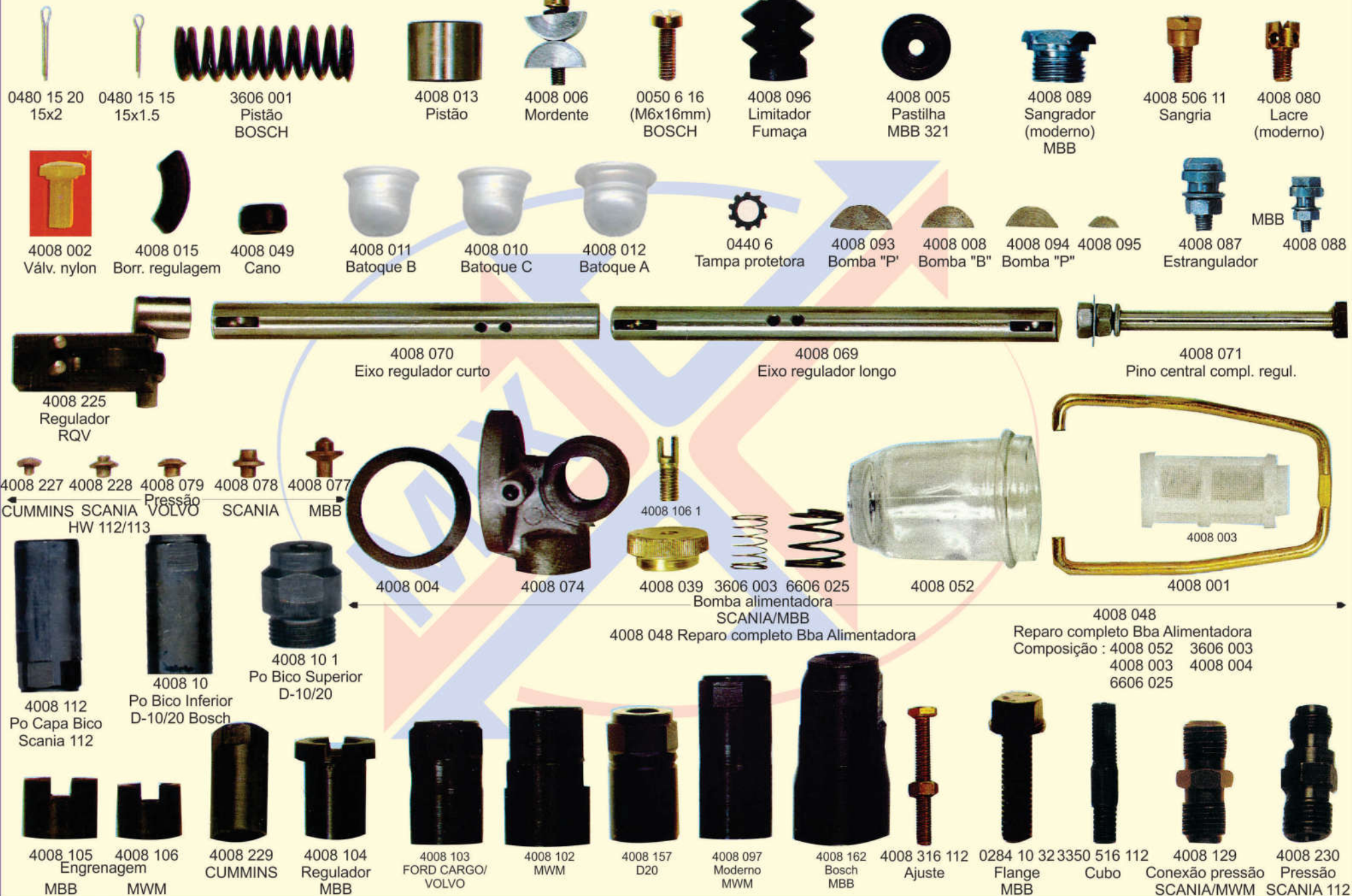

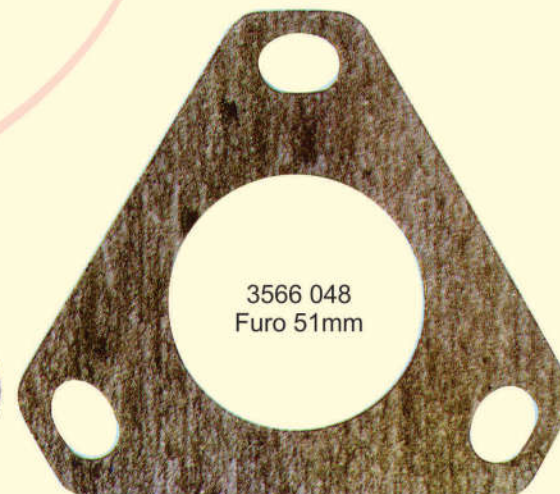
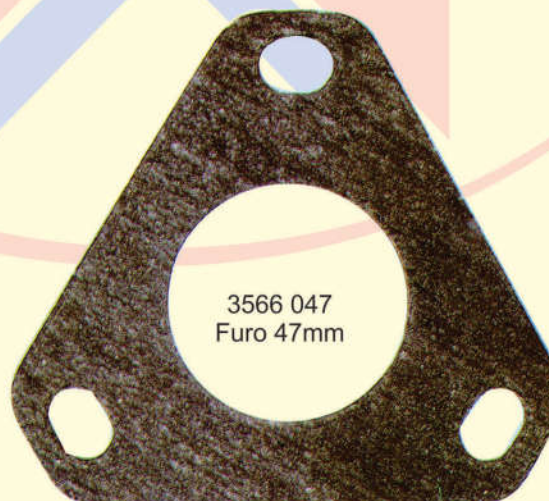
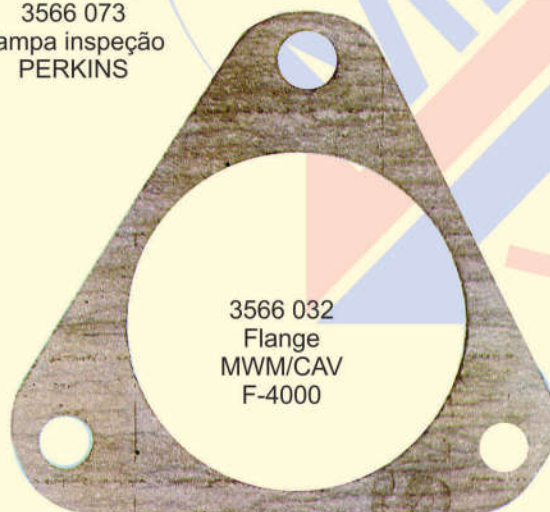
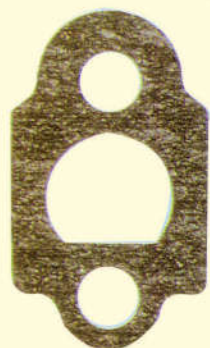
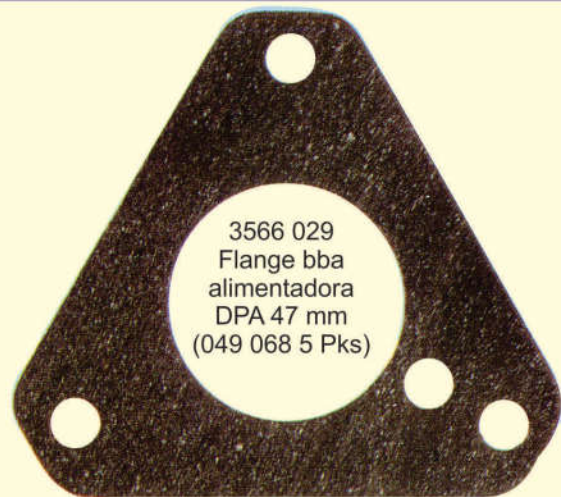

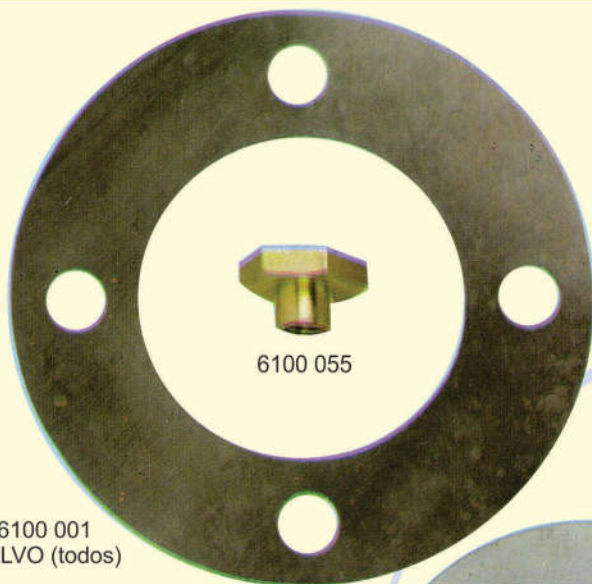

6100 055

6100 001
VOLVO (todos)

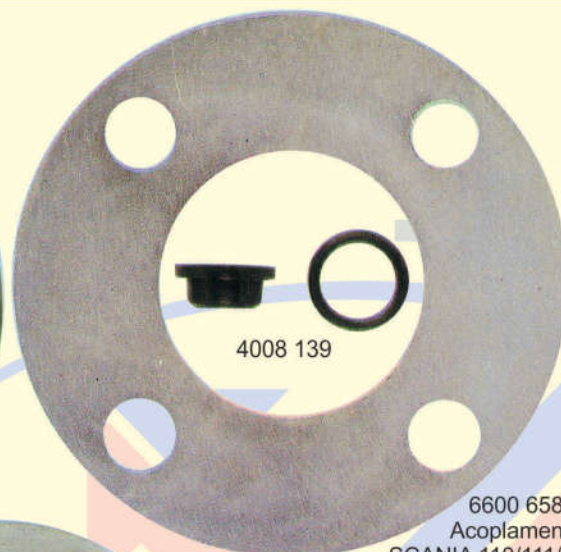

4008 139

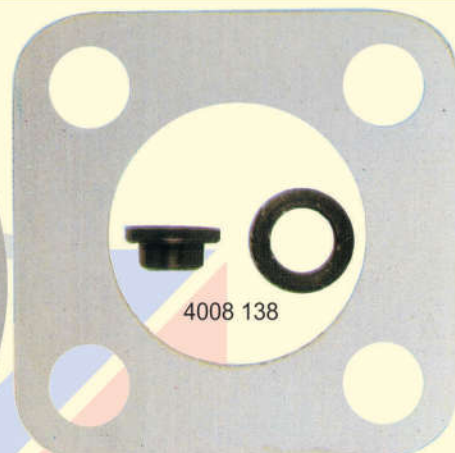

4008 138

6600 658
Acoplamento
SCANIA 110/111/140/141
MBB OM 355/6

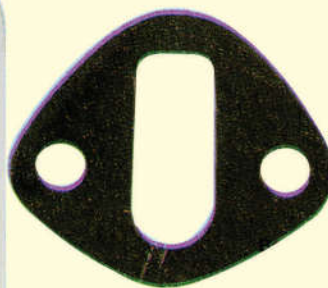

3566 063
Bomba alimentadora
PERKINS



3566 056
Mancal diant.
MBB OM 352

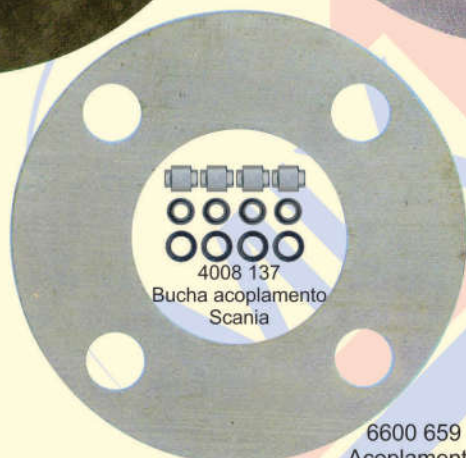

4008 137
Buchas acoplamento
Scania



3566 074
flange bba alimentadora
VE D10

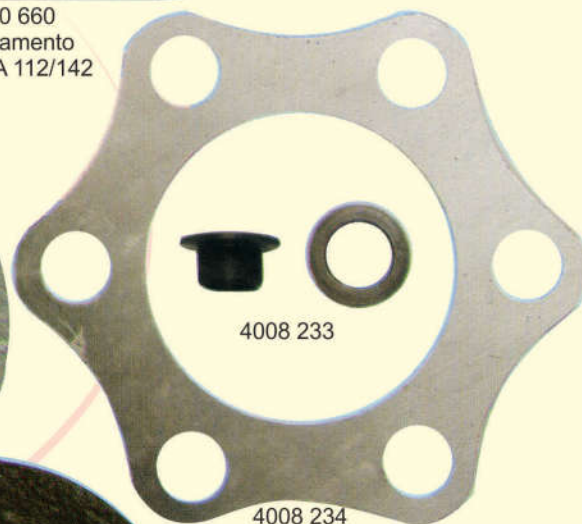

4008 233

4008 234
Acoplamento
SCANIA HW 112/113

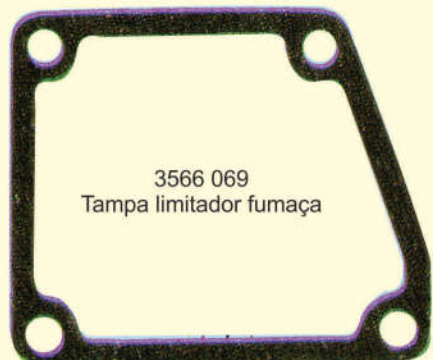

3566 069
Tampa limitador fumaça

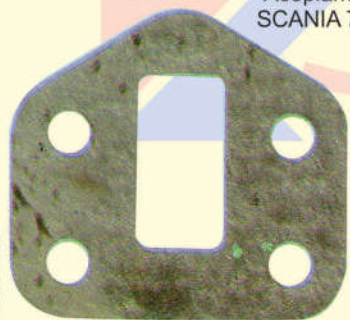

3566 064
Bomba alimentadora D20



3566 057
Tampa regulador
RS/RSV



3566 055
Mancal tras.
MBB OM 352

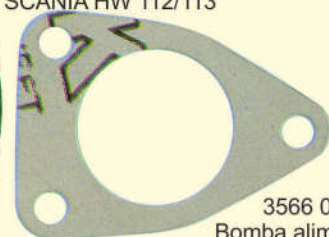

3566 013 1
Bomba alimentadora
SCANIA 110/111/
112
MBB OM 355/6

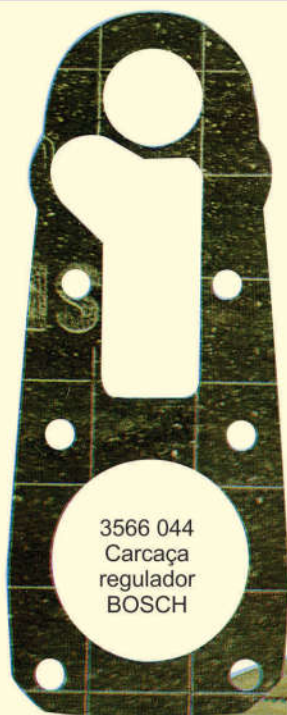

3566 044
Carcaça
regulador
BOSCH



3566 036
Tampa regulador
BOSCH

3566 013
Bomba alim.
BOSCH



3566 007
Tampa lateral
BOSCH 6cc

3566 042
Coletor admissão
VALMET/MWM



3566 035
Tampa lateral
4 cil.

3566 001
Rabicho menor
BOSCH

3566 002
Rabicho maior
BOSCH

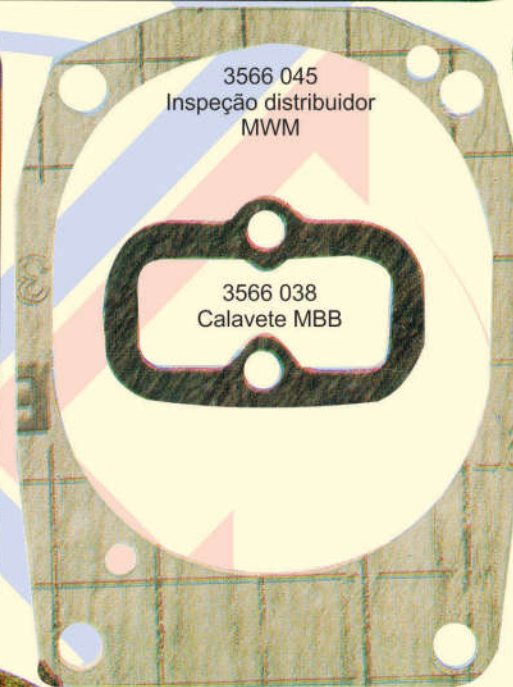

3566 045
Inspeção distribuidor
MWM

3566 038
Calavete
MBB

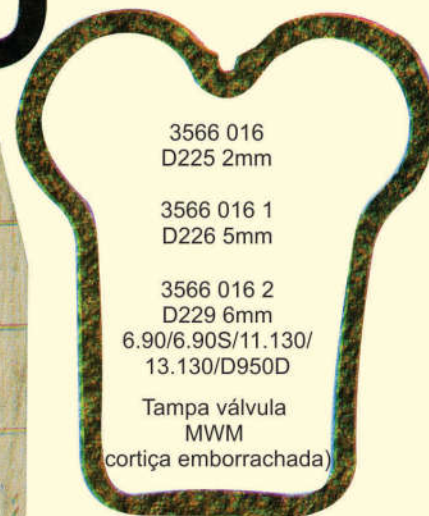

3566 016
D225 2mm

3566 016 1
D226 5mm

3566 016 2
D229 6mm
6.90/6.90S/11.130/
13.130/D950D

Tampa válvula
MWM
cortiça emborrachada)

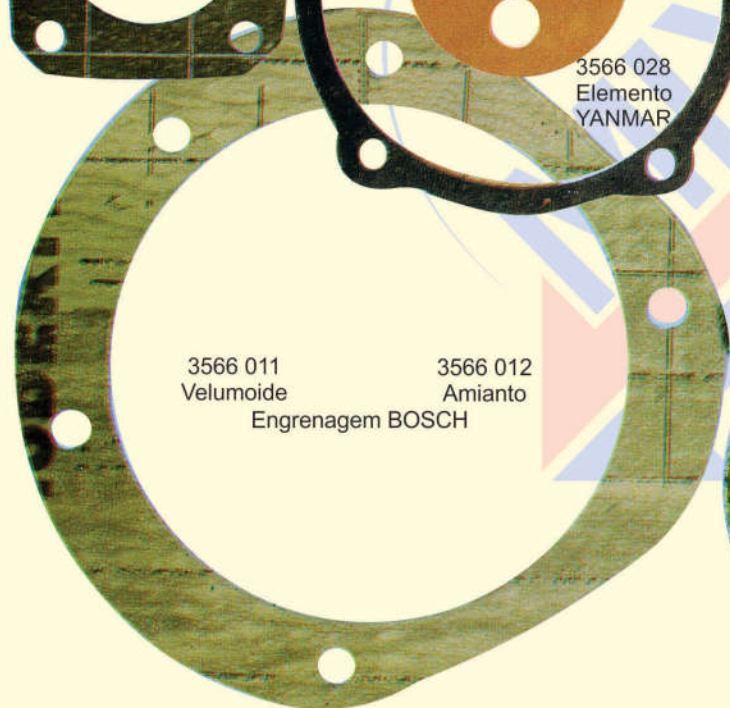

3566 011
Velumóide
Engrenagem BOSCH

3566 012
Amianto



3566 046
Tampa inspeção
distribuição
PERKINS

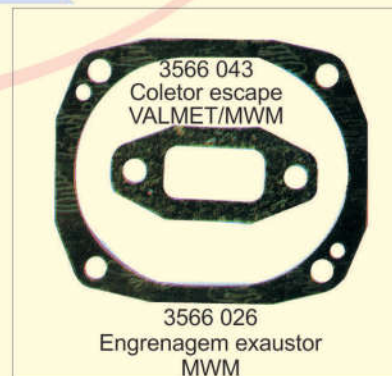

3566 043
Coletor escape
VALMET/MWM

3566 026
Engrenagem exaustor
MWM



3566 010
Tampa
RQ/RQV
BOSCH

3566 014
Flange bomba
MWM



3566 052
Assento inferior
SSB 112B
série 7000



0515 1
2 Canos
MWM



0552 606 2
2 Canos (nylon)



0552 606 3
3 Canos



0552 616 3
3 Canos



0552 616 2
2 Canos



0552 616 4
4 Canos



6600 810
Bomba auxiliar manual



6600 813 (1 litro)
6600 814 (1/2 litro) Par
6600 830 (3/4 litro)
Filtro



4008 14 390
Flexivel Filtro/Bomba
Om352/314/355/355A
440mm Olhal 14mm

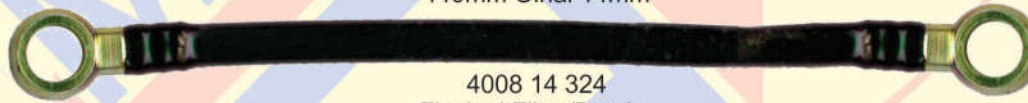

4008 14 324
Flexivel Filtro/Bomba
Om352/314
345mm Olhal 14mm

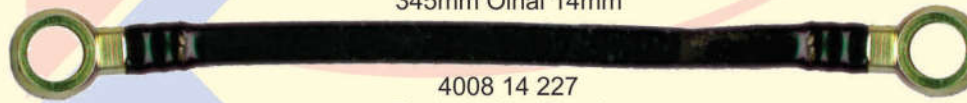

4008 14 227
Flexivel Filtro/Bomba
Om352/352A/355/355A
285mm Olhal 14mm

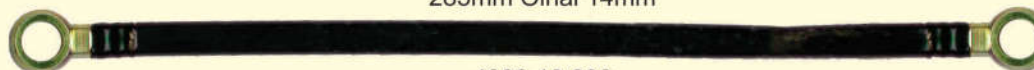

4008 10 290
Flexivel Filtro de Óleo
Om352/352A
330mm Olhal 10mm



ANEIS O'RING

BOMBA INJETORA - 08

OBS: Estes Anéis Estão C/ Imagem Reduzida



0478 5 2
Eixo acel.
Ø 5x2



0478 6 25
Tampa lateral
Ø 6x25



0478 11 3
Válvula 019
Ø 11x3



0478 65 20
Pino roscado
Ø 6.5x20



0478 80 20
válvula reg.
Ø 8x2



0478 86 25
Eixo reg.
Ø 8.6x25



0478 15 24
Buchta regulador.
Ø 15x2.4



0478 150 20
Elemento
Ø 15x2



0478 17 20
Porta válvula
Série 7000
Ø17x2



0478 22 2
Porta válvula
Série 7000
Ø 22x2



0478 260 30
Avanço
Ø 26x3



0478 60 18
Eixo
acelerador
(Ø 6,07x1,78)



0476 108 18
Pf. avanço
(Ø 10,82x1,78)



6357 130 25
Eixo comando Perkins
(Ø 13x2,5)



6357 124 26
Eixo comando Perkins
(Ø 12.37x2.62)



0478 17 18
Avanço
(Ø 17x1.78)



0478 315 35
Cabeçote
(Ø 31.5x35)



0478 55 2
Suporte rolamento
avanço
Ø 5.5x2

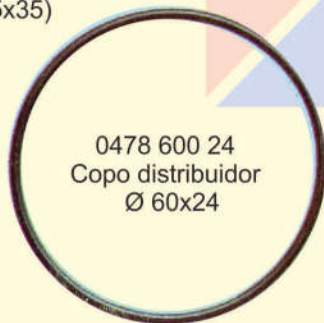

0478 600 24
Copo distribuidor
Ø 60x24



0478 67 26
Mancal
Ø 67x2.6

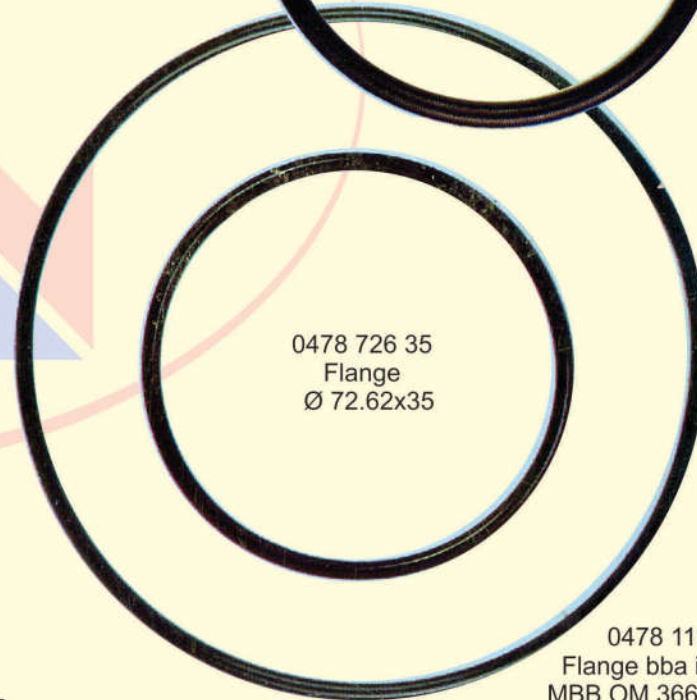

0478 726 35
Flange
Ø 72.62x35

0478 75 3
Suporte rolamento
Ø 75x3



0478 565 360
Flange
(Ø 56.5x3.6)
F-4000/TRATOR FORD

0478 118 3
Flange bba injetora
MBB OM 366 Ø 118x3



CAV

BOMBA INJETORA - 09

